

TB 9-4931-217-40

CHANGE 1

DEPARTMENT OF THE ARMY TECHNICAL BULLETIN

CALIBRATION PROCEDURE FOR RESISTANCE

BRIDGE, ESI MODEL 230B;

AC GENERATOR DETECTOR, ESI MODEL 860A;

AC/DC GENERATOR DETECTOR, ESI MODEL 865A;

IMPEDANCE BRIDGE, ESI MODELS 290A AND B;

DC GENERATOR DETECTOR, ESI MODEL 801;

AND KELVIN RESISTANCE BRIDGE,

ESI MODEL SP2979

Headquarters, Department of the Army, Washington, DC

14 August 2007

Distribution Statement A: Approved for public release; distribution is unlimited.

TB 9-4931-217-40, 31 May 2007, is changed as follows:

1. Remove old pages and insert new pages as indicated below. New or changed material is indicated by a vertical bar in the margin of the page.

Remove Pages

9 and 10

Insert Pages

9 and 10

2. File this change sheet in front of the publication for reference purposes.

By Order of the Secretary of the Army:

Official

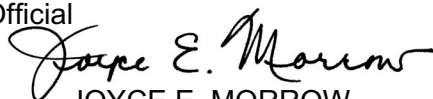

JOYCE E. MORROW

Administrative Assistant to the
Secretary of the Army

0716502

GEORGE W. CASEY, JR.
General, United States Army
Chief of Staff

Distribution:

To be distributed in accordance with STD IDS No. RLC-1500, 2 January 2003, requirements for calibration procedure TB 9-4931-217-40.

*TB 9-4931-217-40

DEPARTMENT OF THE ARMY TECHNICAL BULLETIN

CALIBRATION PROCEDURE FOR RESISTANCE BRIDGE, ESI MODEL 230B; AC GENERATOR DETECTOR, ESI MODEL 860A; AC/DC GENERATOR DETECTOR, ESI MODEL 865A; IMPEDANCE BRIDGE, ESI MODELS 290A AND B; DC GENERATOR DETECTOR, ESI MODEL 801; AND KELVIN RESISTANCE BRIDGE, ESI MODEL SP2979

Headquarters, Department of the Army, Washington, DC
31 May 2007

Distribution Statement A: Approved for public release; distribution is unlimited.

REPORTING OF ERRORS AND RECOMMENDING IMPROVEMENTS

You can improve this manual. If you find any mistakes or if you know of a way to improve these procedures, please let us know. Mail your letter or DA Form 2028 (Recommended Changes to Publications and Blank Forms) directly to Commander, US Army Aviation and Missile Command, ATTN: AMSAM-MMC-MA-NP, Redstone Arsenal, AL 35898-5000. A reply will be furnished to you. You may also provide DA Form 2028 information to AMCOM via e-mail, fax, or the World Wide Web. Our FAX number is: DSN 788-6546 or Commercial 256-842-6546. Our e-mail address is: 2028@redstone.army.mil. Instructions for sending an electronic 2028 may be found at the back of this manual. For the World Wide Web, use: <https://amcom2028.redstone.army.mil>.

SECTION		Paragraph	Page
I.	IDENTIFICATION AND DESCRIPTION		
	Test instrument identification	1	3
	Forms, records, and reports.....	2	3
	Calibration description	3	3
II.	EQUIPMENT REQUIREMENTS		
	Equipment required	4	5
	Accessories required.....	5	6
III.	CALIBRATION PROCESS FOR RESISTANCE BRIDGE, MODEL 230B		
	Preliminary instructions.....	6	7
	Equipment Setup	7	8
	Rheostat arm zero resistance and calibration....	8	8

*This bulletin supersedes TB 9-4931-217-35, 30 April 1980, including all changes.

	Paragraph	Page
Ratio arm calibration	9	11
Final procedure	10	11
 IV. CALIBRATION PROCESS FOR AC GENERATOR DETECTOR, MODEL 860A		
Preliminary instructions.....	11	12
Equipment setup	12	12
Generator frequency and detector selectivity	13	12
Detector sensitivity	14	14
Final procedure	15	15
 V. CALIBRATION PROCESS FOR IMPEDANCE BRIDGE, MODELS 290A AND 290B		
Preliminary instructions.....	16	15
Equipment setup	17	16
Range switch and main dial tracking	18	16
Series capacitance	19	20
Parallel capacitance	20	21
D-Q dial linearity	21	21
Series inductance	22	23
Parallel inductance	23	23
Final procedure	24	24
 VI. CALIBRATION PROCESS FOR DC GENERATOR DETECTOR, MODEL 801		
Preliminary instructions.....	25	24
Equipment setup	26	25
Generator output voltage.....	27	25
Null detector (range accuracy)	28	26
Final procedure	29	28
 VII. CALIBRATION PROCESS FOR AC/DC GENERATOR DETECTOR, MODEL 865A		
Preliminary instructions.....	30	28
Equipment setup	31	29
Ac generator.....	32	30
Ac balance	33	30
Ac detector sensitivity.....	34	31
Final procedure	35	31
 VIII. CALIBRATION PROCESS FOR KELVIN RESISTANCE BRIDGE, MODEL SP2979		
Preliminary instructions.....	36	31
Equipment setup	37	32
Deviation calibration	38	33
100 ohm decade linearization.....	39	34
1,000 ohm decade linearization.....	40	36

	Paragraph	Page
10,000 ohm decade linearization.....	41	38
100,000 ohm decade linearization.....	42	39
Multiplier.....	43	40
Final procedure	44	43

**SECTION I
IDENTIFICATION AND DESCRIPTION**

1. Test Instrument Identification. This bulletin provides instructions for the calibration of Resistance Bridge, ESI Model 230B; Ac Generator Detector, ESI Model 860A; Ac/dc Generator Detector, ESI Model 865A; Impedance Bridge, ESI Models 290A and B; Dc Generator detector, ESI Model 801; and Kelvin Resistance Bridge, ESI Model SP2979. The manufacturers’ manuals were used as prime data sources in compiling these instructions. The equipment being calibrated will be referred to as the TI (test instrument) throughout this bulletin.

a. Model Variations. Variations among models are described in text.

b. Time and Technique.

(1) The technique used in calibrating the TI is the dc (direct current) and low frequency technique.

(2) The approximate time required to calibrate each TI is listed in (a) through (g) below:

- (a) Model 230B..... 3 hours
- (b) Model 860A..... 2 hours
- (c) Model 865A..... 3 hours
- (d) Model 290A..... 5 hours
- (e) Model 290B..... 5 hours
- (f) Model 801..... 3 hours
- (g) Model SP2979..... 5 hours

2. Forms, Records, and Reports

a. Forms, records, and reports required for calibration personnel at all levels are prescribed by TB 750-25.

b. Adjustments to be reported are designated (R) at the end of the sentence in which they appear. When adjustments are in tables, the (R) follows the designated adjustment. Report only those adjustments made and designated with (R).

3. Calibration Description. TI parameters and performance specifications, which pertain to this calibration, are listed in table 1.

Table 1. Calibration Description

Test instrument parameters	Performance specifications
Model 230B	
Rheostat arm zero resistance	0.04 Ω max
Resistance: Rheostat arm	Range: 0.9 to 110,010 Ω Accuracy: ±(0.005% + dial div)
Ratio arm	Range: 0.9999 to 100,010 Ω Accuracy: ±0.005%
Model 860A	
Generator frequency	1 kHz ±1%
Detector selectivity	Response down at least 30 dB at 2d harmonic
Detector sensitivity	20 μ V to 10 mV (indicated on null meter and electron ray tube)
Model 865A	
Generator frequency	Range: Dc to 1 kHz Accuracy: ±1%
Detector sensitivity	5 μ V
Model 290A and 290B	
Resistance (R)	Range: 0 to 1,200 kilohms in 7 ranges Accuracy: ±0.1% +1 dial division for highest range; ±0.05% +1 dial division for other five ranges; ±0.1% +1 dial division for lowest range
Conductance (G)	Range: 0 to 1,200 milimhos in 7 ranges Accuracy: ±0.1% +1 dial division for highest range; ±0.05% +1 dial division for other five ranges; ±0.1% +1 dial division for lowest range
Inductance (L): ¹ Series	Range: 0 to 1,200 henrys in 7 ranges Accuracy: ±0.2% +1 dial division +1.2% X f _{kHz} /Q for highest range; ±0.1% +1 dial division +0.7% X f _{kHz} /Q for other five ranges; ±0.2% +1 dial division +0.7% X f _{kHz} /Q for lowest range Range: Q = 0 to 10.5 X f _{kHz} in 3 ranges Accuracy: ±0.012 f _{kHz} (1 + Q ²) +0.02Q for highest; ±0.012 f _{kHz} (1 + Q ²) +0.02Q for other five and lowest ranges
Parallel	Range: 0 to 1,200 henrys in 7 ranges Accuracy: ±0.2% +1 dial division +1.2% X D X f _{kHz} for highest range; ±0.1% +1 dial division +0.7% X D X f _{kHz} for other five ranges; ±0.2% +1 dial division +0.7% X D X f _{kHz} for lowest range Range: D = 0 to 10.5 x f _{kHz} in 3 ranges Accuracy: ±0.012 f _{kHz} (1 + D ²) +0.02D for highest range; ±0.007 f _{kHz} (1 + D ²) +0.02D for other five and lowest range

See footnotes at end of table.

Table 1. Calibration Description – Continued

Test instrument parameters	Performance specifications
Capacitance (C): ¹ Series	Range: 0 to 1,200 microfarads in 7 ranges Accuracy: $\pm 0.2\% + 1$ dial division $+ 0.5\% X D X f_{kHz}$ for highest range; $\pm 0.1\% + 1$ dial division $+ 0.5\% X D X f_{kHz}$ for other five ranges; $\pm 0.2\% + 1$ dial division $+ 1.0\% X D X f_{kHz}$ for lowest range Range: $D = 0$ to $10.5 x f_{kHz}$ in 3 ranges Accuracy: $\pm 0.005 f_{kHz} (1 + D^2) + 0.02D$ for highest and other five ranges; $\pm 0.010 f_{kHz} (1 + D^2) + 0.02D$ for lowest range
Parallel	Range: 0 to 1,200 microfarads in 7 ranges Accuracy: $\pm 0.2\% + 1$ dial division $+ 0.5\% X D X f_{kHz}/Q$ for highest range; $\pm 0.1\% + 1$ dial division $+ 0.5\% X D X f_{kHz}/Q$ for other five ranges; $\pm 0.2\% + 1$ dial division $+ 1.0\% X D X f_{kHz}/Q$ for lowest range Range: $Q = 0$ to $10.5 x f_{kHz}$ in 3 ranges Accuracy: $\pm 0.005 f_{kHz} (1 + Q^2) + 0.02Q$ for highest and other five ranges; $\pm 0.010 f_{kHz} (1 + Q^2) + 0.02Q$ for lowest range
Multiplier	Range: X0.01, X0.1, X100 Accuracy: ± 2 ppm Range: X1, X10 Accuracy: ± 1 ppm
Model 801	
Generator output	0 to 600 V dc
Null detector	Range: $\pm 3 \mu V$ to $\pm 1000 V$ dc Accuracy: $\pm (5\% + 0.1 \mu V)$
Model SP 2979	
Deviation linearity	± 1 dial div
Resistance decades ²	Range: 100 Ω Accuracy: ± 2 ppm Range: 1 k Ω , 100 k Ω Accuracy: ± 1.5 ppm Range: 10 k Ω Accuracy: ± 1 ppm

¹Accuracy specifications for inductors and capacitance standards apply for units with reasonably high Q (low D) at frequencies near 1 kHz. Nominal frequency range is 100 Hz to 10 kHz, with slight accuracy derating near the limits.

²Accuracy verified as a function of linearity.

SECTION II EQUIPMENT REQUIREMENTS

4. Equipment Required. Table 2 identifies the specific equipment used in this calibration procedure. This equipment is issued with Secondary Reference Standards Calibration - Set, NSN 4931-00-621-7878, and is to be used in performing this procedure. Alternate items may be used by calibrating activity when equipment listed in table 2 is not available. The items selected must be verified to perform satisfactorily prior to use and must bear evidence of current calibration. The equipment must meet or exceed minimum use specifications listed in table 2. The accuracies listed in table 2 provide a four-to-one ratio between standard and TI. Where the four-to-one ratio cannot be met, the actual accuracy of the equipment selected is shown in parenthesis.

TB 9-4931-217-40

5. Accessories Required. The accessories required for this calibration are common usage accessories, issued as indicated in paragraph 4 above, and are not listed in this calibration procedure. The following peculiar accessories are also required for this calibration: Two, No. 14 AWG, insulated, untinned, single copper conductor wires, (MIL-WW-76, HWC14-1U0); Fixed resistor, 10 Ω , 1 W, 5%.

Table 2. Minimum Specifications of Equipment Required

Common name and/or (official nomenclature)	Minimum use specifications	Manufacturer and model (part number)
AC GENERATOR DETECTOR	1	Electro Scientific, Model 860AMOD (7904456-2)
AC/DC GENERATOR DETECTOR	1	Electro Scientific, Model 865A
AUTOTRANSFORMER	Range: 105 to 125 V ac Accuracy: $\pm 1\%$	Ridge, Model 9020A (9020A)
CALIBRATOR	Range: 2.75 mV to 1050 V dc Accuracy: $\pm 0.276\%$	Fluke, Model 5720A (5700A/EP) (p/o MIS-35947); w/ amplifier, Fluke 5725A/AR (5725A/AR)
CAPACITANCE STANDARD	Value: 0.1 μ F Accuracy: $\pm 0.03\%$ or test report value	Arco Electronic, Model SS-32 (7907233)
DC GENERATOR DETECTOR	1	Electro Scientific, Model 801MOD (7912151-2)
DC VOLTAGE DIVIDER	Range: 1 to 0.001 Accuracy: 1 ppm	Electro Scientific, Model RV722 (RV722)
FIXED INDUCTANCE STANDARD	Value: 100 mH Accuracy: $\pm 0.04\%$ or test report value	General Radio, Model 1482L (8205518)
FREQUENCY COUNTER	Range: 990 to 2020 Hz Accuracy: $\pm 0.25\%$	Fluke, Model PM6681/656 (PM6681/656)
FUNCTION/ARBITRARY GENERATOR	Range: 990 to 2020 Hz Output level: 0.01 to 200 mV	Agilent, Model 33250A (33250A)
MULTIMETER	Range: 1.6 to 670 V (dc) 0.035 to 6 V (ac) Accuracy: $\pm 1.66\%$	Hewlett-Packard, Model 3458A (3458A)
RESISTANCE BRIDGE (GUARDED RESISTANCE BRIDGE)	1	Electro Scientific, Model 230B (7912150-2)
RESISTANCE MEASURING SYSTEM	Range: 0.9 to 110,010 Ω Accuracy: $\pm 0.00125\%$	Electro Scientific, Model SP2980 (MIS-10281)
RESISTANCE STANDARD NO. 1	Range: 10 Ω to 110 k Ω Accuracy: $\pm 0.033\%$	Biddle-Gray, Model 71-631 (7910328)
RESISTANCE STANDARD NO. 2	Range: 10 k Ω nominal with certificate Stability: 1 ppm (short term) Accuracy: $\pm 0.00025\%$	General Radio, Model 1444 (MIS-10400)
RESISTOR STANDARD NO. 1	Value: 1 Ω Accuracy: $\pm 0.02\%$	Leeds and Northrop, Model 4020B (8616289)
RESISTOR STANDARD NO. 2	Value: 10 Ω Accuracy: $\pm 0.02\%$	Leeds and Northrop, Model 4025B (8616290)

See footnote at end of table.

Table 2. Minimum Specifications of Equipment Required - Continued

Common name and/or (official nomenclature)	Minimum use specifications	Manufacturer and model (part number)
RESISTOR STANDARD NO. 3	Value: 100 Ω Accuracy: ±0.02%	Leeds and Northrop, Model 4030B (8616291)
RESISTOR STANDARD NO. 4	Value: 1 kΩ Accuracy: ±0.02%	Leeds and Northrop, Model 4035B (8616292)
RESISTOR STANDARD NO. 5	Value: 10 kΩ Accuracy: ±0.02%	Leeds and Northrop, Model 4040B (8616293)
RESISTOR STANDARD NO. 6	Value: 100 kΩ Accuracy: ±0.02%	Leeds and Northrop, Model 4045B (7907139)

¹Calibrated unit normally used in impedance measuring system with TI.

SECTION III CALIBRATION PROCESS FOR RESISTANCE BRIDGE, MODEL 230B

6. Preliminary Instructions

- a. The instructions outlined in paragraphs 6 and 7 are preparatory to calibration process. Personnel should become familiar with the entire bulletin before beginning the calibration.
- b. Items of equipment used in this procedure are referenced within the text by common name as listed in table 2.
- c. Unless otherwise specified, verify the result of each test and, whenever the test requirement is not met, take corrective action before continuing with the calibration. Additional maintenance information is contained in the manufacturers' manuals.
- d. Unless otherwise specified, all controls and control settings refer to TI.

WARNING

HIGH VOLTAGE is used or exposed during the performance of this calibration. DEATH ON CONTACT may result if personnel fail to observe safety precautions. REDUCE OUTPUT(S) to minimum after each step within the performance check where applicable.

NOTE

Do not remove TI protective cover except when necessary to access to internal test points or adjustments. Reinstall protective cover immediately after completion of performance check or adjustment.

- e. Prepare worksheet in accordance with sample shown in table 3.

Table 3 . Sample Ratio Arm Worksheet

Test instrument range switch position	Resistance measuring system indication (ohms)		Computed ratio
	Optimum value	Measured resistance value	
1 MILLIOHMS	1	1.000019 (X1)	$\frac{X1}{X6b} = 1.00000 \times 10^{-5}$
2 OHMS	10	10.000100 (X2)	$\frac{X1}{X6b} = 0.99999 \times 10^{-4}$
3 OHMS	100	100.0018 (X3)	$\frac{X3}{X6b} = 1.00000 \times 10^{-3}$
4 OHMS	1,000	1,000.011 (X4)	$\frac{X4}{X6b} = 0.99999 \times 10^{-2}$
5 KILOHMS	10,000	10,000.13 (X5)	$\frac{X5}{X6b} = 1.00000 \times 10^{-1}$
6 KILOHMS	100,000	100,001.1 (X6a)	$\frac{X6a}{X6b} = 0.99999$
6 KILOHMS ¹	100,000	100,001.7 (X6b)	
7 KILOHMS	10,000	10,000.11 (X7)	$\frac{X6a}{X7} = 1.00000 \times 10^1$
8 MEGOHMS	1,000	1,000.012 (X8)	$\frac{X6a}{X8} = 1.00000 \times 10^2$
9 MEGOHMS	100	100.0013 (X9)	$\frac{X6a}{X9} = 1.00000 \times 10^3$
10 MEGOHMS	10	9.999990 (X10)	$\frac{X6a}{X10} = 1.000012 \times 10^4$
11 GIGOHMS	1	1.000027 (X11)	$\frac{X6a}{X11} = 0.99998 \times 10^5$

¹Use connection C of figure 1 for remaining switch positions (6 through 11).

7. Equipment Setup

- a. Disconnect and remove TI from impedance measuring system.
- b. Turn resistance indication dials and range switch through entire range at least 3 times.

8. Rheostat Arm Zero Resistance and Calibration

a. Performance Check

- (1) Turn all resistance indicating dials to 0 (zero) and range switch to **11 GIGOHMS**.
- (2) Connect equipment as shown in figure 1, connection A.
- (3) Measure and record lead and wiper arm resistance (zero resistance). Measured resistance will not exceed 0.04 ohm.
- (4) Turn resistance indicating dials to settings listed in table 4 and measure resistance at each setting. Subtract zero-resistance value recorded in (3) above from each resistance measurement. Difference will be within specified limits in table 4.

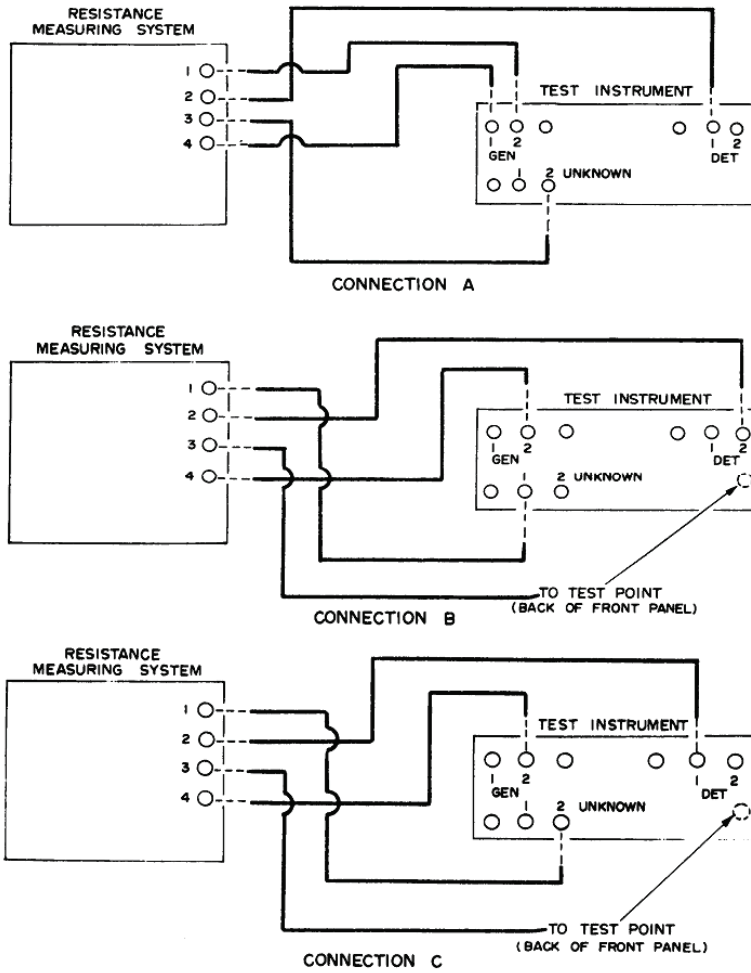

Figure 1. Bridge resistance - equipment setup.

Table 4. Rheostat Arm Accuracy

Test instrument resistance indicating (significant) dial settings					Resistance measuring system indications (ohms)	
Most	2d most	3rd most	4th most	Vernier control	Min	Max
0	0	0	0	00	- - -	0.04
0	0	0	0	10	0.9	1.1
0	0	0	0	20	1.9	2.1
0	0	0	0	30	2.9	3.1
0	0	0	0	40	3.9	4.1
0	0	0	0	50	4.9	5.1
0	0	0	0	60	5.9	6.1
0	0	0	0	70	6.9	7.1
0	0	0	0	80	7.9	8.1
0	0	0	0	90	8.9	9.1
0	0	0	0	100 (Δ)	9.9	10.1

Table 4. Rheostat Arm Accuracy - Continued

Test instrument resistance indicating (significant) dial settings					Resistance measuring system indications (ohms)	
Most	2d most	3rd most	4th most	Vernier control	Min	Max
0	0	0	0	00 ¹	- - -	0.04
0	0	0	1	00	9.9995	10.0005
0	0	0	2	00	19.999	20.001
0	0	0	3	00	29.9985	30.0015
0	0	0	4	00	39.998	40.002
0	0	0	5	00	49.9975	50.0025
0	0	0	6	00	59.997	60.003
0	0	0	7	00	69.9965	70.0035
0	0	0	8	00	79.996	80.004
0	0	0	9	00	89.9955	90.0045
0	0	0	TEN	00	99.995	100.005
0	0	1	0	00	99.995	100.005
0	0	2	0	00	199.99	200.01
0	0	3	0	00	299.985	300.015
0	0	4	0	00	399.98	400.02
0	0	5	0	00	499.975	500.025
0	0	6	0	00	599.97	600.03
0	0	7	0	00	699.965	700.035
0	0	8	0	00	799.96	800.04
0	0	9	0	00	899.955	900.045
0	0	TEN	0	00	999.95	1,000.05
0	1	0	0	00	999.95	1,000.05
0	2	0	0	00	1,999.9	2,000.1
0	3	0	0	00	2,999.85	3,000.15
0	4	0	0	00	3,999.8	4,000.2
0	5	0	0	00	4,999.75	5,000.25
0	6	0	0	00	5,999.7	6,000.3
0	7	0	0	00	6,999.65	7,000.35
0	8	0	0	00	7,999.6	8,000.4
0	9	0	0	00	8,999.55	9,000.45
0	TEN	0	0	00	9,999.5	10,000.5
1	0	0	0	00	9,999.5	10,000.5
2	0	0	0	00	19,999.0	20,001.0
3	0	0	0	00	29,998.5	30,001.5
4	0	0	0	00	39,998.0	40,002.0
5	0	0	0	00	49,997.5	50,002.5
6	0	0	0	00	59,997.0	60,003.0
7	0	0	0	00	69,996.5	70,003.5
8	0	0	0	00	79,996.0	80,004.0
9	0	0	0	00	89,995.5	90,004.5
10	0	0	0	00	99,995.0	100,005.0
11	0	0	0	00	109,994.5	110,005.5

¹ Repeat (3) and (4) above for remaining resistance indicating dial settings listed in table 4.

b. Adjustments. No adjustments can be made.

9. Ratio Arm Calibration

a. Performance Check

- (1) Turn all TI resistance indicating dials to 0 (zero) and set range switch to **1 MILLIOHMS**.
- (2) Connect equipment as shown in figure 1, connection B.

NOTE

Allow at least 6 minutes for thermal stabilization before proceeding to (3) below.

- (3) Measure resistance and record value on ratio worksheet (table 3) as X1.

NOTE

Typical values are shown in table 3 for measured resistance and computed ratio. Actual values will vary with each TI.

- (4) Repeat technique of (3) above for remaining range switch positions listed in table 3.

NOTE

Two measurements are required for **6 KILOHMS** range switch position, using connection B of figure 1 and the other, using connection C. These readings are shown on worksheet as X6a and X6b, respectively.

- (5) Using values recorded on ratio arm worksheet, compute ratio range switch position **1 MILLOHMS** to **6 KILOHMS**, using example below. Computed ratio, disregarding power-of-ten notation, will be between 0.99995 and 1.00005.

$$\text{Ratio} = \frac{X1}{X6b}$$

EXAMPLE:

Assume values of X1 and X6b to be 1.000019 and 100,001.7, respectively, then

$$\text{Ratio} = \frac{1.000019}{100,001.7} = 1.000001 \times 10^{-5}$$

- (6) Repeat technique of (5) above for remaining ratios listed in table 3.

b. Adjustments. No adjustments can be made.

10. Final Procedure

- a.** Deenergize and disconnect all equipment.
- b.** Annotate and affix DA label/form in accordance with TB 750-25.

SECTION IV
CALIBRATION PROCESS FOR AC GENERATOR DETECTOR, MODEL 860A

11. Preliminary Instructions

a. The instructions outlined in paragraphs 11 and 12 are preparatory to the calibration process. Personnel should become familiar with the entire bulletin before beginning the calibration.

b. Items of equipment used in this procedure are referenced within the text by common name as listed in table 2.

WARNING

HIGH VOLTAGE is used or exposed during the performance of this calibration. DEATH ON CONTACT may result if personnel fail to observe safety precautions. REDUCE OUTPUT(S) to minimum after each step within the performance check where applicable.

NOTE

Do not remove TI protective cover except when necessary for access to internal test points or adjustments. Reinstall protective cover immediately after completion of performance check or adjustment.

NOTE

Unless otherwise specified, all controls and control settings refer to the TI.

12. Equipment Setup

CAUTION

Disconnect TI from ac power source when removing or reinstating TI protective cover.

- a. Rotate **GEN VOLTAGE** control fully ccw (counterclockwise) to **OFF**.
- b. Connect autotransformer to a 115 V ac (volt alternating current) source and adjust controls for a 115 V ac output.
- c. Connect TI to autotransformer and turn **GEN VOLTAGE** control cw (clockwise) out of **OFF** position. Allow at least 15 minutes for equipment to warm-up and stabilize.

13. Generator Frequency and Detector Selectivity

a. Performance Check

- (1) Rotate **GEN VOLTAGE** control fully ccw to **OFF**.

- (2) Connect lead from chassis to one end of R20 (fig. 2).

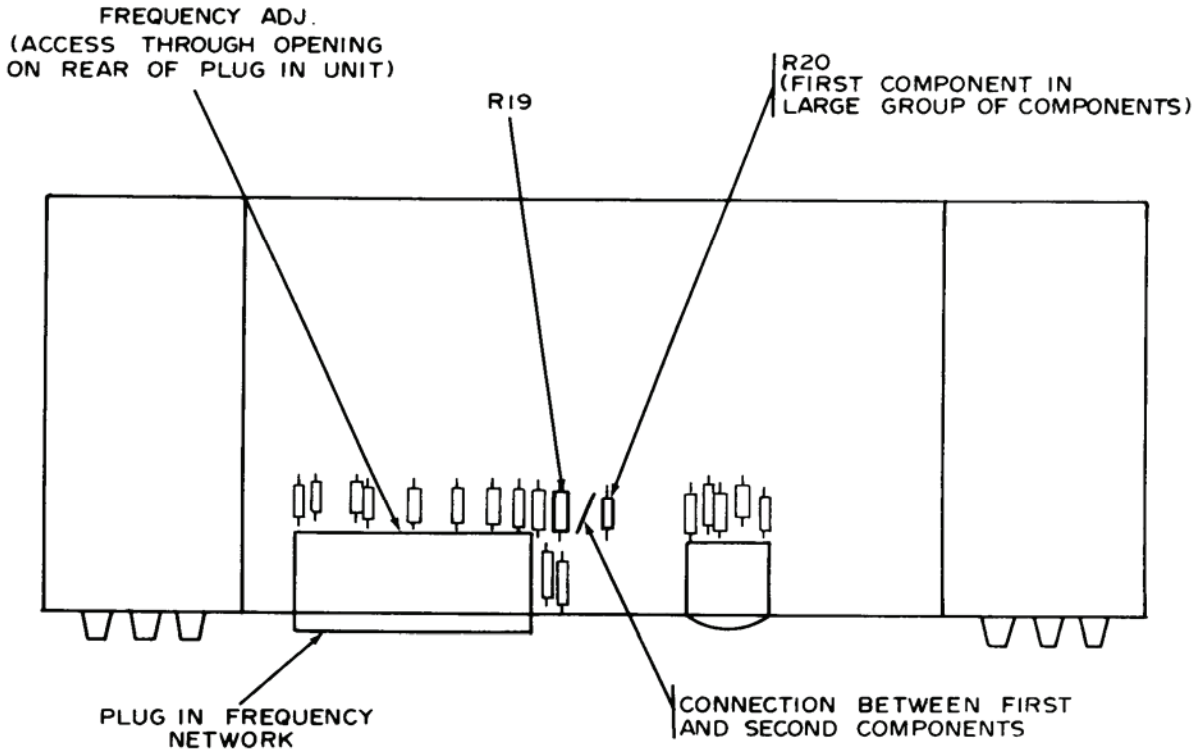

Figure 2. Ac generator detector - top interior view.

- (3) Connect equipment as shown in figure 3.
- (4) Turn **GEN VOLTAGE** control cw out of **OFF** position. Allow at least 5 minutes for equipment to warm up and stabilize.
- (5) Rotate **DET GAIN** control fully ccw.
- (6) Adjust function/arbitrary generator for a 200 mV rms (millivolts root-mean-square) output with frequency at 1 kHz (kilohertz) and output impedance for 50 ohms.
- (7) Move multimeter and cable from **DET INPUT** terminals to **DET OUTPUT** terminals.
- (8) Fine tune function/arbitrary generator frequency control for peak indication on multimeter. Frequency counter will indicate between 990 and 1010 Hz (hertz).
- (9) Adjust **DET GAIN** control between fully ccw and approximately one-fourth turn cw for a convenient multimeter indication. Record multimeter indication.
- (10) Increase function/arbitrary generator frequency until multimeter indication is - 30 dB (decibel) from indication recorded in (9) above. Frequency counter indication will be 2020 Hz or less.

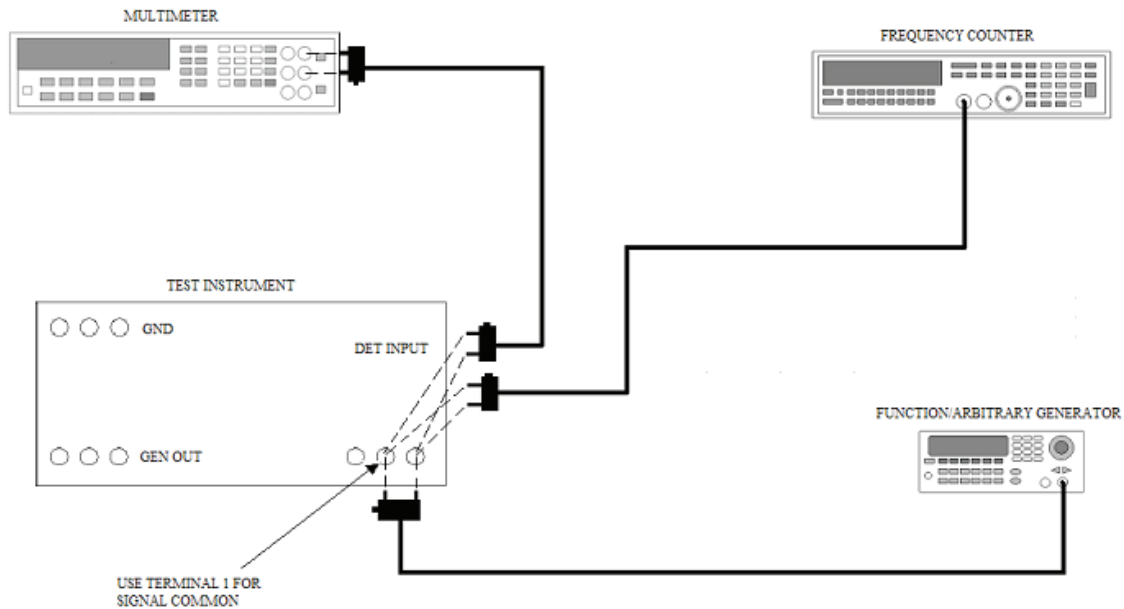

Figure 3. Ac detector sensitivity and selectivity - equipment setup.

(11) Remove frequency counter and cable from equipment setup and lead and adapters connected in (2) above.

(12) Move cable from function/arbitrary generator output terminals and connect to TI **GEN OUTPUT** terminals.

(13) Adjust **GEN VOLTAGE** control for half-scale indication on multimeter.

(14) Adjust **FREQUENCY ADJ** control (fig. 2) for peak indication on multimeter.

b. Adjustments. No further adjustments can be made.

14. Detector Sensitivity

a. Performance Check

(1) Connect TI **DET INPUT** and multimeter input terminals to function/arbitrary generator output terminal.

(2) Turn **GEN VOLTAGE** control ccw but not to **OFF**.

(3) Adjust function/arbitrary generator controls for a 100 mV rms output with frequency at 1 kHz.

(4) Adjust **DET GAIN** control for a convenient indication on TI null meter.

(5) Fine tune function/arbitrary generator frequency for peak indication on TI null meter.

(6) Decrease function/arbitrary generator signal output level by 20 dB.

(7) Adjust **DET GAIN** control for an indication of 4 (full scale) on TI null meter. **DET GAIN** control will be less than fully cw.

- (8) Rotate **DET GAIN** control fully ccw.
 - (9) Adjust function/arbitrary generator for a 200 mV rms output with frequency at 1 kHz.
 - (10) Decrease function/arbitrary generator signal output level by 80 dB.
 - (11) Adjust **DET GAIN** control for a visible indication on **NULL DETECTOR**. **DET GAIN** control will be less than fully cw.
- b. Adjustments.** No adjustments can be made.

15. Final Procedure

- a.** Deenergize and disconnect all equipment.
- b.** Annotate and affix DA label/form in accordance with TB 750-25.

SECTION V CALIBRATION PROCESS FOR IMPEDANCE BRIDGE, MODELS 290A AND 290B

16. Preliminary Instructions

- a.** The instructions outlined in paragraphs **16** and **17** are preparatory to the calibration process. Personnel should become familiar with the entire bulletin before beginning the calibration.
- b.** Items of equipment used in this procedure are referenced within the text by common name as listed in table 2.

WARNING

HIGH VOLTAGE is used or exposed during the performance of this calibration. **DEATH ON CONTACT** may result if personnel fail to observe safety precautions. **REDUCE OUTPUT(S)** to minimum after each step within the performance check where applicable.

NOTE

Do not remove TI protective cover except when necessary for access to internal test points or adjustments. Reinstall protective cover immediately after completion of performance check or adjustment.

NOTE

Unless otherwise specified, all controls and control settings refer to the TI.

17. Equipment Setup

- a. Disconnect and remove TI from impedance measuring system.
- b. Connect TI to dc generator detector, using cable, shield, and ground plugs supplied with TI.
- c. Turn dc generator detector **GENERATOR POWER LIMIT** control to **25 MILLIWATTS**.
- d. Press dc generator detector **ON/OFF** pushbutton to **ON** and allow at least 15 minutes for equipment to warm-up and stabilize.

18. Range Switch and Main Dial Tracking

a. Performance Check

- (1) Position controls as listed in (a) through (c) below:
 - (a) **FUNCTION** switch to **R**.
 - (b) **RANGE** switch to 10^{-4} **k Ω** .
 - (c) **MAIN DIAL** to **0.0000**.
- (2) Connect TI **UNKNOWN** terminals **1** and **2** to one terminal of resistor standard no. 1, using two wires.
- (3) Set dc generator detector **GENERATOR RANGE** switch to **100** and **DETECTOR SENSITIVITY** control fully ccw to **CALIBRATED** position.
- (4) Position dc generator detector controls as listed in (a) through (c) below:
 - (a) **DETECTOR RANGE** switch to **1000 VOLTS**.
 - (b) **GENERATOR OUTPUT +/-OFF/-** switch to **+** (positive).
 - (c) **DETECTOR RANGE** switch ccw for a convenient indication on dc generator detector, null meter.
- (5) Adjust **MAIN DIAL** for a null indication on dc generator detector null meter.

NOTE

When dc generator detector null meter fluctuations are visible, determine average value for fluctuations and consider this value to be dc generator detector null meter indication.

- (6) Set dc generator detector **GENERATOR OUTPUT +/-OFF/-** switch to **OFF** and adjust **DETECTOR ZERO** control until null meter indicates 0 (zero).
- (7) Repeat (4) (b) and (c) through (6) above until dc generator detector null meter indicates best null indication with **GENERATOR OUTPUT +/-OFF/-** switch set to **+** (positive) and 0 (zero) with switch set to **OFF**.
- (8) Set dc generator detector **DETECTOR RANGE** switch to **1000 MILLIVOLTS**.
- (9) Convert **MAIN DIAL** and **RANGE** switch indications to resistance and record value.

NOTE

A dash(-), in the position of a control indication, represents the number 10 in that position.

- (10) Turn **MAIN DIAL** to **9.9(-)00**.
- (11) Connect TI **UNKNOWN** terminals **1** and **2** to potential terminals of resistor standard no. 1, using wire.
- (12) Repeat (4) (b) and (c), and (5) through (9) above

NOTE

When nominal value of resistor being measured is 1000 ohm or greater, subtraction of lead resistance is not required. Round off vernier control indications to nearest multiple of 10.

NOTE

Minimum and maximum values listed are applicable when test report values equal nominal values. If test report value is different from nominal value, this difference must be combined with values recorded in (9) and (12) above.

- (13) Subtract value recorded in (9) above from value recorded in (12) above. Resistance value obtained will be within limits specified in table 5.
- (14) Repeat technique of (11) through (13) above, using resistors, switch settings, and indications listed in table 5.

NOTE

Set dc generator detector **GENERATOR RANGE** switch to a setting that corresponds to 10 times nominal value of resistor connected to **UNKNOWN**.

Table 5. Range Switch Accuracy

Resistor connected to UNKNOWN terminals common name (table 2)	Test instrument			
	RANGE Switch		Resistance value obtained in paragraph 18 a above (Ω)	
	Nominal value	Position (Ω)	Min	Max
Resistor Standard No. 1	1	10^{-4} k	0.9990	1.0010
Resistor Standard No. 2	10	10^{-3} k	9.9950	10.0050
Resistor Standard No. 3	100	10^{-2} k	99.950	100.050
Resistor Standard No. 4	1 k	10^{-1} k	999.5	1000.5
Resistor Standard No. 4	1 k	1 k ²	999.5	1000.5
Resistor Standard No. 5	10 k	1 k ¹	9.995 k	10.005 k
Resistor Standard No. 5	10 k	10 k ²	9.995 k	10.005 k
Resistor Standard No. 6	100 k	10 k ¹	99.95 k	100.05 k
Resistor Standard No. 6	100 k	100 k ²	99.9 k	100.1 k

¹Use an initial **MAIN DIAL** setting of either **9.9(-)00** or **9.9900** when obtaining resistance value on this **RANGE** position.
²Repeat (14) above, using an initial **MAIN DIAL** setting of either **0.9(-)00** or **0.9900**.

NOTE

Range switch on resistance bridge is not effective in the following equipment setup.

(15) Connect TI **UNKNOWN** terminal **1** to **UNKNOWN** terminal **4** of resistance measuring system.

(16) Connect TI **UNKNOWN** terminal **2** to **GENERATOR** terminal **2** of resistance measuring system.

(17) Set **RANGE** switch to **1 kΩ** (kilohm).

(18) Set resistance measuring system dials to 001000.010.

(19) Turn **MAIN DIAL** to **0.9(-)00**.

(20) Repeat (4) (b) and (c) through (8) above. Adjust only the two least significant **MAIN DIAL** controls for best null indication. **MAIN DIAL** indication will be within limits specified in table 6.

(21) Repeat technique of (18) through (20) above, using settings and indications listed in table 6.

Table 6. Most Significant Dial Calibration

Resistance measuring system dial settings	Test instrument MAIN DIAL .		
	Initial settings	Indications when null is obtained	
		Min	Max
001000.010	0.9(-)00	0.9994	0.9(-)06
002000.010	1.9(-)00	1.9989	1.9(-)11
003000.010	2.9(-)00	2.9984	2.9(-)16
004000.010	3.9(-)00	3.9979	3.9(-)21
005000.010	4.9(-)00	4.9974	4.9(-)26
006000.010	5.9(-)00	5.9969	5.9(-)31
007000.010	6.9(-)00	6.9964	6.9(-)36
008000.010	7.9(-)00	7.9959	7.9(-)41
009000.010	8.9(-)00	8.9954	8.9(-)46
010000.010	9.9(-)00	9.9949	9.9(-)51
011000.010	10.9(-)00	10.9944	10.9(-)56
012000.010	11.9(-)00	11.9939	11.9(-)61

(22) Set **RANGE** switch to **10 kΩ**.

(23) Set resistance measuring system dials to 001000.010.

(24) Turn **MAIN DIAL** to **0.09(-)0**.

(25) Repeat (4) (b) and (c) through (8) above. Adjust only the two least significant **MAIN DIAL** controls for best null indication. **MAIN DIAL** indication will be within limits specified in table 7.

(26) Repeat technique of (23) through (25) above, using settings and indications listed in table 7.

Table 7. Second Most Significant Dial Calibration

Resistance measuring system dial settings	Test instrument MAIN DIAL		
	Initial settings	Indications when null is obtained	
		Min	Max
001000.010	0.09(-)0	0.0998	0.09(-)2
002000.010	0.19(-)0	0.1998	0.19(-)2
003000.010	0.29(-)0	0.2997	0.29(-)3
004000.010	0.39(-)0	0.3997	0.39(-)3
005000.010	0.49(-)0	0.4996	0.49(-)4
006000.010	0.59(-)0	0.5996	0.59(-)4
007000.010	0.69(-)0	0.6995	0.69(-)5
008000.010	0.79(-)0	0.7995	0.79(-)5
009000.010	0.89(-)0	0.8994	0.8(-)06
010000.010	0.99(-)0	0.9994	0.9(-)06
011000.010	0.(-)9(-)0	0.(-)993	0.(-)07

(27) Set resistance measuring system dials to 000100.010.

(28) Turn **MAIN DIAL** to **0.00 (-)0**.

(29) Repeat (4) (b) and (c) through (8) above. Adjust only the least significant **MAIN DIAL** control for best null indication. **MAIN DIAL** indication will be within limits specified in table 8.

(30) Repeat technique of (27) through (29) above using settings and indications listed in table 8.

Table 8. Third Most Significant Dial Calibration

Resistance measuring system dial settings	Test instrument MAIN DIAL		
	Initial settings	Indications when null is obtained	
		Min	Max
000100.010	0.00(-)0	0.0099	0.00(-)1
000200.010	0.01(-)0	0.0199	0.01(-)1
000300.010	0.02(-)0	0.0299	0.02(-)1
000400.010	0.03(-)0	0.0399	0.03(-)1
000500.010	0.04(-)0	0.0499	0.04(-)1
000600.010	0.05(-)0	0.0599	0.05(-)1
000700.010	0.06(-)0	0.0699	0.06(-)1
000800.010	0.07(-)0	0.0799	0.07(-)1
000900.010	0.08(-)0	0.0899	0.08(-)1
001000.010	0.09(-)0	0.0998	0.09(-)2
001100.010	0.9(-)0	0.9(-)98	0.9(-)2

(31) Set **RANGE** switch to **100 kΩ**.

(32) Set resistance measuring system dials to 000100.010.

(33) Turn **MAIN DIAL** to 00010.

(34) Repeat (4) (b) and (c) through (8) above. Adjust only the least significant **MAIN DIAL** control for best null indication. **MAIN DIAL** indication will be within limits specified in table 9.

TB 9-4931-217-40

(35) Repeat technique (32) through (34) above, using settings and indications listed in table 9.

Table 9. Fourth Most Significant Dial Calibration

Resistance measuring system dial settings	Test instrument MAIN DIAL		
	Initial settings	Indications when null is obtained	
		Min	Max
000100.010	0.0010	0.0009	0.0011
000200.010	0.0020	0.0019	0.0021
000300.010	0.0030	0.0029	0.0031
000400.010	0.0040	0.0039	0.0041
000500.010	0.0050	0.0049	0.0051
000600.010	0.0060	0.0059	0.0061
000700.010	0.0070	0.0069	0.0071
000800.010	0.0080	0.0079	0.9981
000900.010	0.0090	0.0089	0.0091
001000.010	0.00(-)0	0.0099	0.00(-)1

b. Adjustments. No adjustments can be made.

19. Series Capacitance

a. Performance Check

(1) Connect ac generator detector to TI, using terminal straps and shields provided with ac generator detector.

(2) Rotate ac generator detector **DET GAIN** control fully ccw.

(3) Turn ac generator detector **GEN VOLTAGE** control ccw but not to **OFF**. Allow at least 15 minutes for equipment to warm-up and stabilize.

(4) Position controls as listed in (a) through (e) below:

(a) **FUNCTION** switch to **C SERIES**.

(b) **RANGE** switch to $10^{-2} \mu\text{F}$.

(c) **MAIN DIAL** to **9.9950**.

(d) **D-Q** multiplier switch to **.001X**.

(e) **D-Q** dial to **10**.

(5) Connect capacitance standard to TI **UNKNOWN** terminals **1** and **2**, using banana plugs provided with capacitance standard.

(6) Rotate ac generator detector **GEN VOLTAGE** control fully cw.

(7) Adjust ac generator detector **DET GAIN** control for a convenient indication on null meter.

(8) Alternately adjust **MAIN DIAL** and **D-Q** dial for a null indication on ac generator detector null meter.

(9) Repeat (7) and (8) above for best null indication on ac generator detector null meter.

(10) Convert **MAIN DIAL** and **RANGE** switch indications to capacitance using example below. If value obtained is not within $\pm(0.1\% +1 \text{ dial division})$ of capacitance standard test report value perform **b** (1) through (3) below.

EXAMPLE:

RANGE switch = $10^{-2} \mu\text{F}$
 MAIN DIAL = 9.9842
 Capacitance = $9.9842 \times 10^{-2} \mu\text{F}$
 = 0.099842 μF

(11) Rotate ac generator detector **DET GAIN** control ccw.

b. Adjustments

(1) Turn **MAIN DIAL** to indicate capacitance standard test report value.

(2) Remove cap (near **D-Q ADJ** terminals) covering internal adjustment. Adjust internal control and **D-Q** dial for best null indication on ac generator detector null meter. Reinstall internal adjustment cover.

(3) Rotate ac generator detector **DET GAIN** control fully ccw.

20. Parallel Capacitance

a. Performance Check

(1) Set **FUNCTION** switch to **PARALLEL C**.

(2) Connect capacitance standard to **TI UNKNOWN** terminals **1** and **2** and connect resistance standard no. 1 to capacitance standard terminals.

(3) Adjust resistance standard controls to 1,000 ohms.

(4) Turn **MAIN DIAL** to **9.9900** and **D-Q** multiplier switch to **1X**.

(5) Adjust ac generator detector **DET GAIN** control for a convenient indication on null meter.

(6) Alternately adjust **MAIN DIAL** and **D-Q** dial for a null indication on ac generator detector null meter.

(7) Rotate generator detector **DET GAIN** control fully ccw.

b. Adjustments. No adjustments can be made.

21. D-Q Dial Linearity

a. Performance Check

(1) Position controls as listed in (a) through (d) below:

(a) **FUNCTION** switch to **C SERIES**.

(b) **RANGE** switch to $10^{-2} \mu\text{F}$.

TB 9-4931-217-40

- (c) **MAIN DIAL** to **10.0000**.
- (d) **D-Q** multiplier switch to **.001X**.
- (2) Connect capacitance standard to TI **UNKNOWN** terminals **1** and **2**.
- (3) Adjust **D-Q** dial for best null indication on ac generator detector meter.
- (4) Record **D-Q** dial indication and subtract from all subsequent measurements.
- (5) Connect capacitance standard and resistance standard no. 1 in series, and connect to TI **UNKNOWN** terminals **1** and **2**.
- (6) Adjust resistance standard controls to 15.0 ohms.
- (7) Adjust ac generator detector **DET GAIN** control for a convenient indication on null detector.

NOTE

A broad undefined change corresponding to **MAIN DIAL** change in normal.

- (8) Alternately adjust **MAIN DIAL** and **D-Q** dial for a null indication on ac generator detector null meter.
- (9) Repeat (7) and (8) above for best null indication on null meter. **D-Q** dial will indicate within limits specified in table 10.
- (10) Rotate ac generator detector **DET GAIN** control fully ccw
- (11) Repeat technique of (6) through (10) above, using settings and indications listed in table 10.

Table 10. **D-Q** Dial Linearity

Test instrument D-Q switch settings	Resistance standard indications (ohms)	Test instrument D-Q dial indications	
		Min	Max
.001X	15.0	9	11
.001X	31.8	19	21
.001X	47.7	29	31
.001X	63.7	39	41
.001X	79.6	49	51
.001X	96.5	59	61
.001X	111.4	69	71
.001X	127.3	79	81
.001X	143.2	89	91
.001X	159.2	99	101
.01X	159	9	11
.01X	318	19	21
.01X	477	29	31
.01X	637	39	41
.01X	796	49	51
.01X	955	59	61

Table 10. **D-Q** Dial Linearity- Continued

Test instrument D-Q switch settings	Resistance standard Indications (ohms)	Test instrument D-Q dial indications	
		Min	Max
.01X	1114	69	71
.01X	1273	79	81
.01X	1432	89	91
.01X	1592	99	101
.1X	1.59 k	9	11
.1X	3.18 k	19	21
.1X	4.77 k	29	31
.1X	6.37 k	39	41
.1X	7.96 k	49	51
.1X	9.55 k	59	61
.1X	11.14 k	69	71
.1X	12.73 k	79	81
.1X	14.32 k	89	91
.1X	15.92 k	99	101

b. Adjustments. No adjustments can be made.

22. Series Inductance

a. Performance Check

- (1) Position controls as listed in (a) through (c) below:
 - (a) **FUNCTION** switch to **SERIES L**.
 - (b) **RANGE** switch to **10⁻¹ H**.
 - (c) **MAIN DIAL** to **1.0000**.
- (2) Connect fixed inductance standard to TI **UNKNOWN** terminals **1** and **2**.
- (3) Adjust ac generator detector **DET GAIN** control for a convenient indication on null meter.
- (4) Adjust **MAIN DIAL** and **D-Q** dial for null indication on ac generator detector null meter.
- (5) Repeat (3) and (4) above for best null indication on null meter.
- (6) Convert **MAIN DIAL** and **RANGE** switch indications to inductance. Results obtained will be within $\pm(0.1\% + 1 \text{ dial division})$ of induction test report value.
- (7) Rotate ac generator detector **DET GAIN** control fully ccw.

b. Adjustments. No adjustments can be made.

23. Parallel Inductance

a. Performance Check

- (1) Set **D-Q** multiplier switch to **.01X** and **FUNCTION** switch to **L PARALLEL**.

TB 9-4931-217-40

(2) Adjust ac generator detector **DET GAIN** control for a convenient indication on null meter.

(3) Alternately adjust **MAIN DIAL** and **D-Q** dial for a null indication on ac generator detector meter.

(4) Repeat (2) and (3) above as required. It will be possible to obtain a sharp null on null detector.

(5) Rotate ac generator detector **DET GAIN** and **GEN VOLTAGE** controls fully ccw.

b. Adjustments. No adjustments can be made.

24. Final Procedure

a. Deenergize and disconnect all equipment.

b. Annotate and affix DA label/form in accordance with TB 750-25.

**SECTION VI
CALIBRATION PROCESS FOR DC GENERATOR DETECTOR MODEL 801**

25. Preliminary Instructions

a. The instructions outlined in paragraphs **25** and **26** are preparatory to the calibration process. Personnel should become familiar with the entire bulletin before beginning the calibration.

b. Items of equipment used in this procedure are referenced within the text by common name as listed in table 2.

WARNING

HIGH VOLTAGE is used or exposed during the performance of this calibration. DEATH ON CONTACT may result if personnel fail to observe safety precautions. REDUCE OUTPUT(S) to minimum after each step within the performance check where applicable.

NOTE

Do not remove TI protective cover except when necessary for access to internal test points. or adjustments. Reinstall protective cover immediately after completion of performance check or adjustment.

NOTE

Unless otherwise specified, all controls and control settings refer to the TI.

26. Equipment Setup

- a. Disconnect TI from impedance measuring system.
- b. Connect autotransformer to a 115 V ac source and adjust controls for a 115 V output.
- c. Connect TI to autotransformer.
- d. Press **ON/OFF** pushbutton to **ON** and allow at least 15 minutes for equipment to warm-up and stabilize.
- e. Press **ON/OFF** pushbutton to **OFF**. After 1 minute adjust TI meter mechanical zero adjustment as necessary to position pointer on 0 (zero).

27. Generator Output Voltage

a. Performance Check

- (1) Press **ON/OFF** pushbutton to **ON** and allow at least 5 minutes for equipment to warm-up and stabilize.
- (2) Connect positive terminal of multimeter to TI **GENERATOR OUTPUT** terminal 1.
- (3) Connect negative terminal of multimeter to TI **GENERATOR OUTPUT** terminal 2.
- (4) Turn **GENERATOR POWER LIMIT** control to **1000 MILLIWATTS**.
- (5) Set **GENERATOR RANGE** switch to **2 V**.

NOTE

Polarity of voltage at terminal 1 corresponds to **GENERATOR OUTPUT** switch setting.

- (6) Set **GENERATOR OUTPUT +/-OFF/-** switch to **+** (positive). Multimeter will indicate within limits specified in table 11.
- (7) Set **GENERATOR OUTPUT +/-OFF/-** switch to **OFF**.
- (8) Repeat technique of (4) through (6) above, using settings and indications listed in table 11.

b. Adjustments. No adjustments can be made.

Table 11. Dc Generator Output Voltage

Test instrument GENERATOR RANGE switch positions (V)	Multimeter indications (V dc)	
	Min	Max
2	1.6	2.4
6	5.0	7.6
20	16	24
60	50	76
200	160	240
600	500	760
2 ¹	-1.6	-2.4

¹Set **GENERATOR OUTPUT +/-OFF/-** switch - (negative) when performing this check.

28. Null Detector (Range Accuracy)

a. Performance Check

- (1) Connect lead between TI **DETECTOR INPUT** terminals 1 and 2.
- (2) Rotate **DETECTOR SENSITIVITY** control fully ccw to **CALIBRATED** position.
- (3) Set **DETECTOR RANGE** switch to **3 MICROVOLTS**.

NOTE

When TI meter fluctuations are visible, determine average value for fluctuations and consider this value to be meter indication.

- (4) Adjust **DETECTOR ZERO** control for a 0 (zero) indication on TI meter.
- (5) Set **DETECTOR RANGE** switch to **1000** indicate 0 (zero) or less than one minor division on upper scale, perform **b** (1) below.

NOTE

When switching transients are visible (abrupt changes in meter indications), allow indications to stabilize before obtaining final indication.

- (6) Connect equipment as shown in figure 4.
- (7) Turn voltage divider dials to .0010000.
- (8) Adjust calibrator output controls to 0 (zero) and set TI **POWER** switch to **ON**.
- (9) Set **DETECTOR RANGE** switch to **3 MICROVOLTS**.

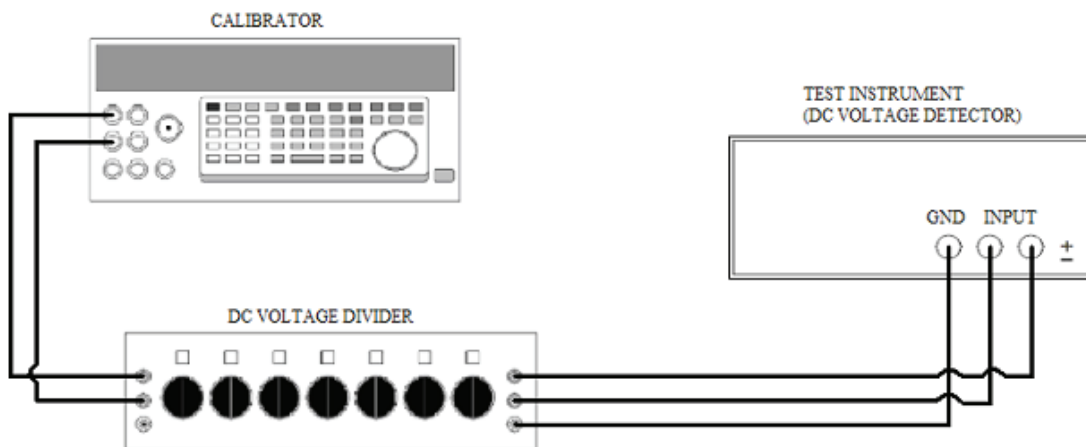

Figure 4. Dc detector voltage range calibration - equipment setup.

(10) Adjust **DETECTOR ZERO** control, if necessary, for a 0 (zero) indication on TI meter.

(11) Adjust calibrator controls for a 3 μ V (microvolt) indication on TI meter. If calibrator does not indicate within limits specified in table 12, perform **b** (2) below.

(12) Adjust calibrator controls for minimum output.

(13) Repeat technique of (9) through (12) above, using settings and indications listed in table 12. If calibrator indications are not within limits specified, perform appropriate adjustments listed in table 12.

b. Adjustments

(1) Adjust A1R14 1V ZERO (fig. 5) for a 0 (zero) indication on TI meter.

(2) Adjust calibrator controls for a 0.003000 V output and adjust A1R41 3 μ V (fig. 5) for a 3 μ V indication on TI meter (R).

Table 12. Meter Accuracy (10 V to 1000 V)

Test instrument		Calibrator indication		Adjustments	
DETECTOR RANGE switch position	Meter indication	(volts dc)		Control (fig. 5)	Calibrator setting
		Min	Max		
3 MICROVOLTS	(μ V) 3	00.00275	00.00325	A1R41 (R) 3 μ V	0.003 V
10 MICROVOLTS	10	00.00940	00.01060	A1R42 (R) 10 μ V	10 V
30 MICROVOLTS	30	00.02840	00.03160	---	---
100 MICROVOLTS	100	00.09490	00.10510	---	---
300 MICROVOLTS	300	00.28490	00.31510	---	---
1000 MICROVOLTS	1000	00.94990	01.05010	A1R43 (R) 1 mV	1000 μ V
3 MILLIVOLTS ¹	(mV) 3	0.002850	0.003150	---	---
10 MILLIVOLTS	10	0.009500	0.010500	---	---
30 MILLIVOLTS	30	0.028500	0.031500	---	---
100 MILLIVOLTS	100	0.095000	0.105000	---	---
100 MILLIVOLTS	80	0.075000	0.085000	---	---
100 MILLIVOLTS	60	0.055000	0.065000	---	---
100 MILLIVOLTS	40	0.035000	0.045000	---	---
100 MILLIVOLTS	20	0.015000	0.025000	---	---
300 MILLIVOLTS	300	0.285000	0.315000	---	---
1000 MILLIVOLTS	1000	0.950000	1.050000	A1R44 (R) 1V	1 μ V
3 VOLTS	(V) 3	002.8500	003.1500	---	---
10 VOLTS	10	009.5000	010.5000	---	---
30 VOLTS	30	028.5000	031.5000	---	---
100 VOLTS	100	095.0000	105.0000	---	---
300 VOLTS		285.0000	315.0000	---	---
1000 VOLTS	1000	950.0000	X50.0000	---	---

¹When **DETECTOR RANGE** switch is set to **3 MILLIVOLTS** or greater, connect calibrator OUTPUT terminals to TI **DET INPUT** terminals 1 and 2.

²Reverse leads to check neg detection on this position only.

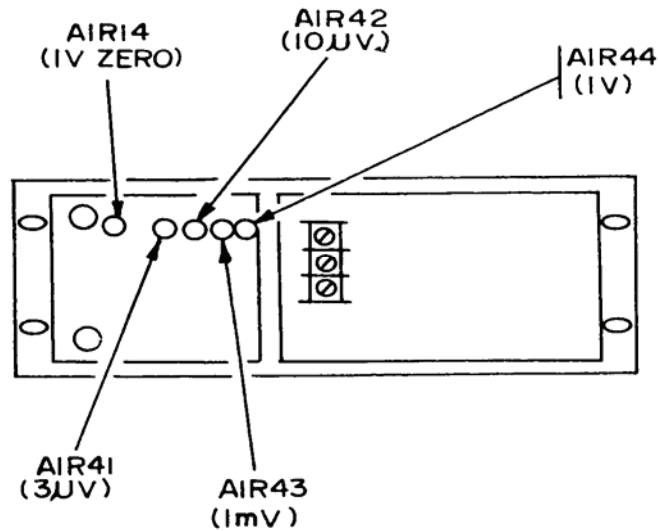

Figure 5. Dc generator detector - rear interior view - adjustment locations.

29. Final Procedure

- a. Deenergize and disconnect all equipment.
- b. Annotate and affix DA label/form in accordance with TB 750-25.

SECTION VII CALIBRATION PROCESS FOR AC/DC GENERATOR DETECTOR, MODEL 865A

30. Preliminary Instructions

- a. The instructions outlined in paragraphs **30** and **31** are preparatory to the calibration process. Personnel should become familiar with the entire bulletin before beginning the calibration.
- b. Items of equipment used in this procedure are referenced within the text by common name as listed in table 2.

WARNING

HIGH VOLTAGE is used or exposed during the performance of this calibration. DEATH ON CONTACT may result if personnel fail to observe safety precautions. REDUCE OUTPUT(S) to minimum after each step within the performance check where applicable.

NOTE

Do not remove TI protective cover except when necessary for access to internal test points or adjustments. Reinstall protective cover immediately after completion of performance check or adjustment.

NOTE

Unless otherwise specified, all controls and control settings refer to TI.

31. Equipment Setup

- a. Connect TI to autotransformer.
- b. Connect autotransformer to a 115 V ac source and adjust controls for a 115 V ac output.
- c. If necessary, adjust mechanical zero-adjust screw, located below TI meter face, for a 0 (zero) indication on TI meter.
- d. Position controls as listed in (1) through (8) below:
 - (1) **FREQUENCY** switch to **DC**.
 - (2) **GENERATOR ON/OFF** switch to **OFF**.
 - (3) **GENERATOR ± Polarity** switch to + (positive)
 - (4) **GENERATOR POWER LIMIT** control to 0 (zero).
 - (5) **DETECTOR SENSITIVITY HIGH/LOW** switch to **HIGH**.
 - (6) **DETECTOR SENSITIVITY** control fully cw.
 - (7) **DETECTOR ZERO** control on midrange.
 - (8) **DETECTOR LOG/LIN** switch to **LIN**.
- e. Connect lead between TI **DETECTOR DC INPUT** terminals **1** and **2**.
- f. Press **ON/OFF** pushbutton to **ON** and allow at least 5 minutes for equipment to warm-up and stabilize.
- g. If TI meter does not indicate 0 (zero) adjust R10 (fig. 6) for a 0 (zero) indication.
- h. Rotate **DETECTOR SENSITIVITY** control fully ccw.
- i. Set **DETECTOR SENSITIVITY HIGH/LOW** switch to **LOW**. If TI meter does not indicate 0 (zero), adjust R19 AC ZERO (fig. 6) for a 0 (zero) indication.
- j. Repeat **d** (5) and (6) and **g** through **i** above until TI meter indicates 0 (zero) in **g** and **i**.
- k. Remove lead connected in **e** above.

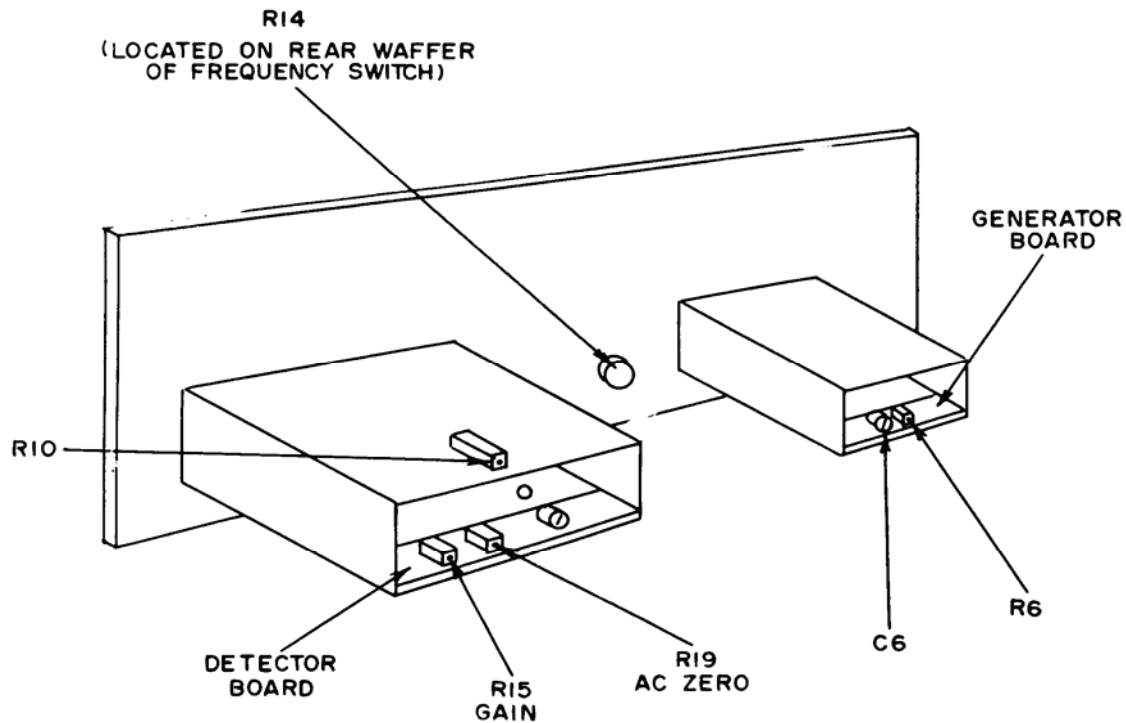

Figure 6. Model 865A - rear internal view.

32. Ac Generator

a. Performance Check

- (1) Set **FREQUENCY** switch to **1 kHz** and rotate **GENERATOR POWER LIMIT** control fully cw.
- (2) Connect multimeter and frequency counter to **TI GENERATOR AC OUTPUT** terminals **1** and **2**.
- (3) Set **GENERATOR ON/OFF** switch to **ON**. If multimeter does not indicate at least **6 V ac**, perform **b** (1) below. If frequency counter does not indicate between **990** and **1,010 Hz (hertz)**, perform **b** (2) below.

b. Adjustments (fig. 6)

- (1) Adjust **R6** for a **6 V ac** indication on multimeter (R).
- (2) Adjust **C6** for a **1 kHz** indication on frequency counter (R).

33. Ac Balance

a. Performance Check

- (1) Press **ON/OFF** pushbutton to **OFF** and adjust **DETECTOR SENSITIVITY** control to midrange.

(2) Connect fixed resistor directly across TI **GENERATOR AC OUTPUT** terminals **1** and **2**.

(3) Connect TI **GENERATOR AC OUTPUT** terminal **2** to TI **DETECTOR AC INPUT** terminal **2**.

(4) Press **ON/OFF** pushbutton to **ON**. Adjust R14 (fig. 6) until meter indicates null (low point, not zero).

(5) Set **GENERATOR** \pm polarity switch alternately between **+** (positive) and **-** (negative). If TI meter indication is not within one minor division in either position, perform **b** below.

b. Adjustments (fig. 6). Set **GENERATOR** \pm polarity switch alternately between **+** (positive) and **-** (negative) while adjusting R14 for same TI meter indication in either position.

34. Ac Detector Sensitivity

a. Performance Check

(1) Connect function/arbitrary generator 50-ohm output terminal to TI **DETECTOR AC INPUT** terminals **1** and **2**, using cable and termination.

(2) Adjust function/arbitrary generator controls for a 100 μ V output with frequency at 1 kHz.

(3) Set **DETECTOR SENSITIVITY HIGH/LOW** switch to **HIGH** and rotate **DETECTOR SENSITIVITY** control fully cw. If TI meter does not indicate full scale, perform **b** below.

(4) Set **DETECTOR SENSITIVITY HIGH/LOW** switch to **LOW**.

(5) Adjust function/arbitrary generator controls for a 10 mV output. TI meter will indicate full scale or near full scale.

b. Adjustments. Adjust R15 **GAIN** (fig. 6) for a full-scale indication on TI meter.

35. Final Procedure

a. Deenergize and disconnect all equipment.

b. Annotate and affix DA label/form in accordance with TB 750-25.

SECTION VIII

CALIBRATION PROCESS FOR KELVIN RESISTANCE BRIDGE, MODEL SP2979

36. Preliminary Instructions

a. The instructions outlined in paragraphs **36** and **37** are preparatory to the calibration process. Personnel should become familiar with the entire bulletin before beginning the calibration.

TB 9-4931-217-40

b. Items of equipment used in this procedure are referenced within the text by common name as listed in table 2.

WARNING

HIGH VOLTAGE is used or exposed during the performance of this calibration. DEATH ON CONTACT may result if personnel fail to observe safety precautions. REDUCE OUTPUT(S) to minimum after each step within the performance check where applicable.

NOTE

Do not remove TI protective cover except when necessary for access to internal test points or adjustments. Reinstall protective cover immediately after completion of performance check or adjustment.

NOTE

To simplify instructions, the combination of dc generator detector and kelvin resistance bridge will be referred to as TI.

37. Equipment Setup

- a. Connect TI to autotransformer.
- b. Connect autotransformer to a 115 V ac source and adjust controls for a 115 V ac output.
- c. Connect equipment as shown in figure 7.

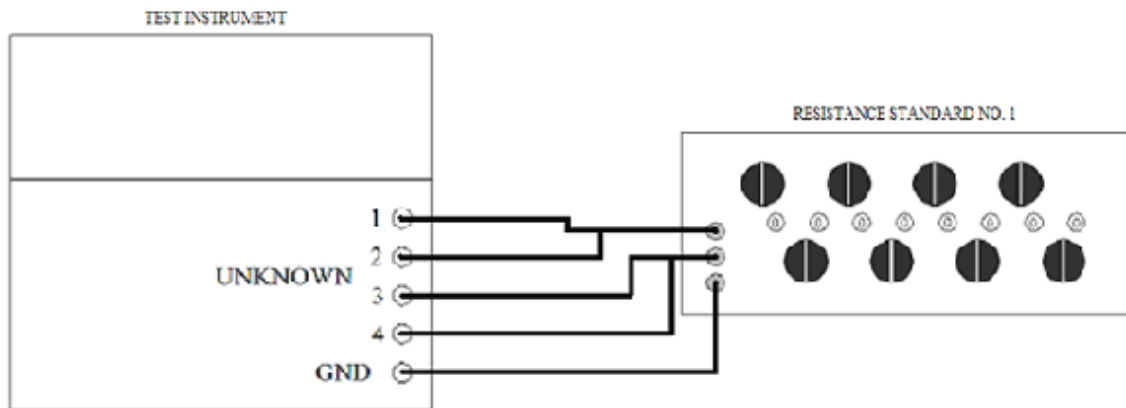

Figure 7. Decade linearization - equipment set.

- d. Position controls as listed in (1) through (8) below:

- (1) **GENERATOR OUTPUT +/-OFF/-** switch to **OFF**.
 - (2) **GENERATOR POWER LIMIT** control to **100 MILLIWATTS**.
 - (3) **GENERATOR RANGE**, switch to **10 kΩ**.
 - (4) **DETECTOR RANGE** switch to **30 MICROVOLTS**.
 - (5) **MULTIPLIER** switch to **1X STANDARD**.
 - (6) **DEVIATION RANGE** switch to **+0.1 ppm**.
 - (7) **DEVIATION** dial to **X0** (verify that index is aligned with 0 (zero)).
 - (8) Resistance decade dials to 009999.
- e. Adjust resistance standard no. 1 to 10,000.00 ohms.

38. Deviation Calibration

a. Performance Check

- (1) Position controls as listed in (a) through (c) below:
 - (a) **DETECTOR ZERO** control for a null indication on TI meter.
 - (b) **DETECTOR RANGE** switch to **30 MILLIVOLTS**.
 - (c) **GENERATOR OUTPUT +/-OFF/-** switch to **+** (positive).
- (2) Adjust resistance decade dials for a null indication on TI meter while decreasing **DETECTOR RANGE** switch to **30 MICROVOLTS**.
- (3) Position controls as listed in (a) through (d) below:
 - (a) **DETECTOR RANGE** switch to **30 MILLIVOLTS**.
 - (b) **GENERATOR OUTPUT +/-OFF/-** switch to **OFF**.
 - (c) **FUNCTION** switch to **LEAD ADJ**.
 - (d) **GENERATOR OUTPUT +/-OFF/-** switch to **+** (positive).
- (4) Adjust **LEAD ADJ** control for a null indication on TI meter while decreasing **DETECTOR RANGE** switch to **30 MICROVOLTS**.
- (5) Position controls as listed in (a) through (d) below:
 - (a) **DETECTOR RANGE** switch to **30 MILLIVOLTS**.
 - (b) **GENERATOR OUTPUT +/-OFF/-** switch to **OFF**.
 - (c) **FUNCTION** switch to **YOKE ADJ**.
 - (d) **GENERATOR OUTPUT +/-OFF/-** switch to **+** (positive).
- (6) Adjust **YOKE ADJ** control for a null indication on TI meter while decreasing **DETECTOR RANGE** switch to **30 MICROVOLTS**.
- (7) Position controls as listed in (a) through (d) below:
 - (a) **DETECTOR RANGE** switch to **30 MILLIVOLTS**.
 - (b) **GENERATOR OUTPUT +/-OFF/-** switch to **OFF**.

TB 9-4931-217-40

(c) **FUNCTION** switch to **NORMAL**.

(d) **GENERATOR OUTPUT +/-OFF/-** switch to + (positive).

(8) Adjust resistance decade dials for a null indication on TI meter while decreasing **DETECTOR RANGE** switch to **30 MICROVOLTS**.

(9) Set **DEVIATION RANGE** switch to **+1 ppm** and **DEVIATION** dial to **X0**. If TI meter does not indicate a null, perform **b (1)** below.

(10) Set **DETECTOR RANGE** switch to **300 MICROVOLTS** and **DEVIATION RANGE** switch to **+0.01%**. If TI meter does not indicate a null, perform **b (2)** below.

(11) Set **DETECTOR RANGE** switch to **3 MILLIVOLTS** and **DEVIATION RANGE** switch to **+0.01%**. If TI does not indicate a null, perform **b (3)** below.

(12) Set **DETECTOR RANGE** switch to **30 MILLIVOLTS** and **GENERATOR OUTPUT +/-OFF/-** switch to **OFF**.

b. Adjustments

NOTE

Remove upper **CALIBRATION TRIMMERS** cover to gain access to adjustments.

(1) Adjust **RANGE 1** trimmer for a null indication on TI meter (R).

(2) Adjust **RANGE 10** trimmer for a null indication on TI meter (R).

(3) Adjust **RANGE 100** trimmer for a null indication on TI meter (R).

39. 100 Ohm Decade Linearization

a. Performance Check

(1) Position controls as listed in (a) through (d) below:

(a) **MULTIPLIER** switch to **100 X STANDARD**.

(b) **DEVIATION RANGE** switch to **+0.1 ppm**.

(c) **DEVIATION** dial to **X0**.

(d) Resistance decade dials to 0000TEN0.01(00).

(2) Adjust **DETECTOR ZERO** control for a null indication on TI meter while decreasing **DETECTOR RANGE** switch to **3 MICROVOLTS** (most sensitive range).

(3) Set **DETECTOR RANGE** switch to **1000 MICROVOLTS** and **GENERATOR OUTPUT +/-OFF/-** switch to + (positive).

(4) Adjust resistance standard no. 1 for a null indication on TI meter while decreasing **DETECTOR RANGE** switch to **3 MICROVOLTS** (most sensitive range).

NOTE

If null indication cannot be obtained using resistance standard, adjust **DEVIATION** dial to complete null indication.

- (5) Position controls as listed in (a) through (d) below:
 - (a) **GENERATOR OUTPUT +/-OFF/-** switch to **OFF**.
 - (b) **DETECTOR RANGE** switch to **1000 MICROVOLTS**.
 - (c) **FUNCTION** switch to **LEAD ADJ**.
 - (d) **GENERATOR OUTPUT +/-OFF/-** switch to **+** (positive).
- (6) Adjust **LEAD ADJ** control for a null indication on TI meter while decreasing **DETECTOR RANGE** switch to **3 MICROVOLTS** (most sensitive ranger).
- (7) Position controls as listed in (a) through (d) below:
 - (a) **GENERATOR OUTPUT +/-OFF/-** switch to **OFF**.
 - (b) **DETECTOR RANGE** switch to **1000 MICROVOLTS**.
 - (c) **FUNCTION** switch to **YOKE ADJ**.
 - (d) **GENERATOR OUTPUT +/-OFF/-** switch to **+** (positive).
- (8) Adjust **YOKE ADJ** control for a null indication on TI meter while decreasing **DETECTOR RANGE** switch to **3 MICROVOLTS** (most sensitive range).
- (9) Position controls as listed in (a) through (c) below:
 - (a) **GENERATOR OUTPUT +/-OFF/-** switch to **OFF**.
 - (b) **DETECTOR RANGE** switch to **1000 MICROVOLTS**.
 - (c) **FUNCTION** switch to **NORMAL**.
- (10) Repeat (2) through (9) above until no further null adjustment is required.
- (11) Turn resistance decade dials to 000100.01(00) and set **GENERATOR OUTPUT +/-OFF/-** switch to **+** (positive).
- (12) Decrease **DETECTOR RANGE** switch setting until **3 MICROVOLTS** range is reached or until a full-scale indication is obtained on TI meter. If TI meter does not indicate null on **3 MICROVOLTS** range, perform **b** below.
- (13) Set **GENERATOR OUTPUT +/-OFF/-** switch to **OFF** and **DEVIATION** dial to **X0**.
- (14) Repeat (3) through (5) (b) and (11) through (13) above, using resistance standard and resistance dial settings listed in table 13. If TI meter does not indicate null on **3 MICROVOLTS** range, perform appropriate adjustment listed in table 13.

Table 13. 100 Ohm Decade Linearization

Step	Resistance standard nominal resistance (k Ω)	Test instrument		
		Resistance decade dial settings ¹		Adjustments (behind lower calibration trimmer cover)
		100 ohms	10 ohms	
1	20	1	TEN	- - -
2	- - -	2	0	100 Ω - 2 (R)
3	30	2	TEN	- - -
4	- - -	3	0	100 Ω - 3 (R)

Table 13. 100 Ohm Decade Linearization - Continued

Step	Resistance standard nominal resistance (k Ω)	Test instrument		
		Resistance decade dial settings ¹		Adjustments (behind lower calibration) trimmer cover)
		100 ohms	10 ohms	
5	40	3	TEN	- - -
6	- - -	4	0	100 Ω - 4 (R)
7	50	4	TEN	- - -
8	- - -	5	0	100 Ω - 5 (R)
9	60	5	TEN	- - -
10	- - -	6	0	100 Ω - 6 (R)
11	70	6	TEN	- - -
12	- - -	7	0	100 Ω - 7 (R)
13	80	7	TEN	- - -
14	- - -	8	0	100 Ω - 8 (R)
15	90	8	TEN	- - -
16	- - -	9	0	100 Ω - 9 (R)
17	100	9	TEN	- - -
18	- - -	10	0	100 Ω - 10 (R)

¹Other resistance decade dials remain as previously positioned.

b. Adjustments. Set **DETECTOR RANGE** switch to **3 MICROVOLTS** and adjust 100fl-1 trimmer for a null indication on TI meter (R).

NOTE

Remove lower calibration trimmers cover to gain access to adjustments.

40. 1,000 Ohm Decade Linearization

a. Performance Check

(1) Set **MULTIPLIER** switch to **10 X STANDARD** and resistance decade dials to 000(TEN)00.01(00).

(2) Adjust resistance standard no. 1 to 10 kΩ.

(3) Set **DETECTOR RANGE** switch to **3 MICROVOLTS** and adjust **DETECTOR ZERO** control for a null indication on TI meter.

(4) Set **DETECTOR RANGE** switch to **1000 MICROVOLTS** and **GENERATOR OUTPUT +/-OFF/-** switch to + (positive).

(5) Adjust resistance standard no. 1 for a null indication on TI meter while decreasing **DETECTOR RANGE** switch to **10 MICROVOLTS**.

NOTE

If null indication cannot be obtained using resistance standard no. 1, adjust **DEVIATION** dial to complete null indication.

(6) Position controls as listed in (a) through (e) below:

(a) **GENERATOR OUTPUT +/-OFF/-** switch to **OFF**.

- (b) **DETECTOR RANGE** switch to **1000 MICROVOLTS**.
- (c) 1k OHMS resistance decade dial to 1.
- (d) 100 OHMS resistance decade dial to 0.
- (e) **GENERATOR OUTPUT +/-OFF/-** switch to + (positive).

(7) Decrease **DETECTOR RANGE** switch setting until **10 MICROVOLTS** range is reached or until a full-scale indication is obtained on TI meter. If TI meter does not indicate null on **10 MICROVOLTS** range, perform **b** below.

(8) Set **GENERATOR OUTPUT +/-OFF/-** switch to **OFF** and **DEVIATION** dial to **X0**.

(9) Repeat (3) through (8) above using resistance standard and resistance decade dial settings listed in table 14. If TI meter does not indicate null on **10 MICROVOLTS** range, perform appropriate adjustment listed in table 14.

Table 14. 1,000-Ohm Decade Linearization

Step	Resistance standard no. 1 nominal resistance (k Ω)	Test instrument		
		Resistance decade dial settings ¹		Adjustments (behind lower calibration) trimmer cover)
		1k ohm	100 ohms	
1	20	1	TEN	- - -
2	- - -	2	0	1000 Ω - 2 (R)
3	30	2	TEN	- - -
4	- - -	3	0	1000 Ω - 3 (R)
5	40	3	TEN	- - -
6	- - -	4	0	1000 Ω - 4 (R)
7	50	4	TEN	- - -
8	- - -	5	0	1000 Ω - 5 (R)
9	60	5	TEN	- - -
10	- - -	6	0	1000 Ω - 6 (R)
11	70	6	TEN	- - -
12	- - -	7	0	1000 Ω - 7 (R)
13	80	7	TEN	- - -
14	- - -	8	0	1000 Ω - 8 (R)
15	90	8	TEN	- - -
16	- - -	9	0	1000 Ω - 9 (R)
17	100	9	TEN	- - -
18	- - -	10	0	1000 Ω - 10 (R)

¹Other resistance decade dials remain as previously positioned.

b. Adjustments. Set **DETECTOR RANGE** switch to **10 MICROVOLTS** and adjust 1000 Ω 1 trimmer for a null indication on TI meter (R).

NOTE

Remove lower CALIBRATION TRIMMERS cover to gain access to adjustments.

41. 10,000 Ohm Decade Linearization

a. Performance Check

- (1) Set **MULTIPLIER** switch to **1 X STANDARD** and resistance decade dials to 00(TEN)000.01(00).
- (2) Adjust resistance standard no. 1 to 10 kΩ.
- (3) Set **DETECTOR RANGE** switch to **3 MICROVOLTS** and adjust **DETECTOR ZERO** control for a null indication on TI meter.
- (4) Set **DETECTOR RANGE** switch to **1000 MICROVOLTS** and **GENERATOR OUTPUT +/-OFF/-** switch to + (positive).
- (5) Adjust resistance standard no. 1 for a null indication on TI meter while decreasing **DETECTOR RANGE** switch to **30 MICROVOLTS**.

NOTE

If null indication cannot be obtained using resistance standard, adjust **DEVIATION** dial to complete null indication.

- (6) Position controls as listed in (a) through (e) below:
 - (a) **GENERATOR OUTPUT +/-OFF/-** switch to **OFF**.
 - (b) **DETECTOR RANGE** switch to **1000 MICROVOLTS**.
 - (c) 10k ohms resistance decade dial to 1.
 - (d) 1k ohms resistance decade dial to 0 (zero).
 - (e) **GENERATOR OUTPUT +/-OFF/-** switch to + (positive).
- (7) Decrease **DETECTOR RANGE** switch setting until **30 MICROVOLTS** range is reached or until a full-scale indication is obtained on TI meter. If TI meter does not indicate null on **30 MICROVOLTS** range, perform **b** below.
- (8) Set **GENERATOR OUTPUT +/-OFF/-** switch to **OFF** and **DEVIATION** dial to **X0**.
- (9) Repeat (3) through (8) above, using resistance standard no. 1 and resistance decade dial settings listed in table 15. If TI meter does not indicate null on **30 MICROVOLTS** range, perform appropriate adjustment listed in table 15.

Table 15. 10,000 Ohm Decade Linearization

Step	Resistance standard nominal resistance (k Ω)	Test instrument		
		Resistance decade dial settings ¹ (ohms)		Adjustments (behind lower calibration trimmers cover)
		10k	1k	
1	20	1	TEN	- - -
2	- - -	2	0	10K Ω - 2 (R)
3	30	2	TEN	- - -
4	- - -	3	0	10K Ω - 3 (R)
5	40	3	TEN	- - -
6	- - -	4	0	10K Ω - 4 (R)
7	50	4	TEN	- - -

See note at end of table.

Table 15. 10,000-ohm Decade Linearization - Continued

Step	Resistance standard nominal resistance (k Ω)	Test instrument		
		Resistance decade dial settings ¹ (ohms)		Adjustments (behind lower calibration trimmers cover)
		10k	1k	
8	- - -	5	0	10K Ω - 5 (R)
9	60	5	TEN	- - -
10	- - -	6	0	10K Ω - 6 (R)
11	70	6	TEN	- - -
12	- - -	7	0	10K Ω - 7 (R)
13	80	7	TEN	- - -
14	- - -	8	0	10K Ω - 8 (R)
15	90	8	TEN	- - -
16	- - -	9	0	10K Ω - 9 (R)
17	100	9	TEN	- - -
18	- - -	10	0	10K Ω - 10 (R)

¹Other resistance decade dials remain as previously positioned.

b. Adjustments. Set **DETECTOR RANGE** switch to **30 MICROVOLTS** and adjust 10k Ω 1 trimmer for a null indication on TI meter (R).

NOTE

Remove lower calibration trimmers cover to gain access to adjustments.

42. 100,000 Ohm Decade Linearization

a. Performance Check

(1) Set **MULTIPLIER** switch to **0.1 X STANDARD** and resistance decade dials to 0(TEN)0000.01(00).

(2) Adjust resistance standard to 10kΩ.

(3) Set **DETECTOR RANGE** switch to **3 MICROVOLTS** and adjust **DETECTOR ZERO** zero control for a null indication on TI meter.

(4) Set **DETECTOR RANGE** switch to **1000 MICROVOLTS** and **GENERATOR OUTPUT +/-OFF/-** switch to + (positive).

(5) Adjust resistance standard for a null indication on TI meter while decreasing **DETECTOR RANGE** switch to **10 MICROVOLTS**.

NOTE

If null indication cannot be obtained using resistance standard, adjust **DEVIATION** dial to complete null indication.

(6) Position controls as listed in (a) through (e) below:

(a) **GENERATOR OUTPUT +/-OFF/-** switch to **OFF**.

(b) **DETECTOR RANGE** switch to **1000 MICROVOLTS**.

(c) 100k ohms resistance decade dial to 1

TB 9-4931-217-40

- (d) 10k ohms resistance decade dial to 0 (zero).
- (e) **GENERATOR OUTPUT +/-OFF/-** switch to + (positive).

(7) Decrease **DETECTOR RANGE** switch to setting until **10 MICROVOLTS** range is reached or until a full-scale indication is obtained on TI meter. If TI meter does not indicate null on **10 MICROVOLTS** range, perform **b** below.

(8) Set **GENERATOR OUTPUT +/-OFF/-** switch to **OFF** and **DEVIATION** dial to **X0**.

(9) Repeat (3) through (8) above, using resistance standard and resistance decade dial settings listed in table 16. If TI meter does not indicate null on **10 MICROVOLTS** range, perform appropriate adjustment listed in table 16.

Table 16. 100,000-Ohm Decade Linearization

Step	Resistance standard nominal resistance (k Ω)	Test instrument		
		Resistance decade dial settings ¹ (ohms)		Adjustments (behind lower calibration trimmers cover)
		100k	10k	
1	20	1	TEN	---
2	---	2	0	100K Ω - 2 (R)
3	30	2	TEN	---
4	---	3	0	100K Ω - 3 (R)
5	40	3	TEN	---
6	---	4	0	100K Ω - 4 (R)
7	50	4	TEN	---
8	---	5	0	100K Ω - 5 (R)
9	60	5	TEN	---
10	---	6	0	100K Ω - 6 (R)
11	70	6	TEN	---
12	---	7	0	100K Ω - 7 (R)
13	80	7	TEN	---
14	---	8	0	100K Ω - 8 (R)
15	90	8	TEN	---
16	---	9	0	100K Ω - 9 (R)
17	100	9	TEN	---
18	---	10	0	100K Ω - 10 (R)
19	110	10	(TEN)	---
20	---	11	0	100K Ω - 11 (R)

¹Other resistance decade dials remain as previously positioned.

b. Adjustments. Set **DETECTOR RANGE** switch to **10 MICROVOLTS** and adjust 100 k Ω 1 trimmer for a null indication on TI meter.

NOTE

Remove lower **CALIBRATION TRIMMERS** cover to gain access to adjustments.

43. Multiplier

a. Performance Check

- (1) Position controls as listed in (a) through (d) below:

- (a) **GENERATOR OUTPUT +/-OFF/-** switch to **OFF**.
 - (b) **MULTIPLIER** switch to **100 X STANDARD**.
 - (c) **DEVIATION RANGE** switch to **+0.1 ppm**.
 - (d) Resistance decade dials to 000099.9 (TEN) (00).
- (2) Connect equipment as shown in figure 8.

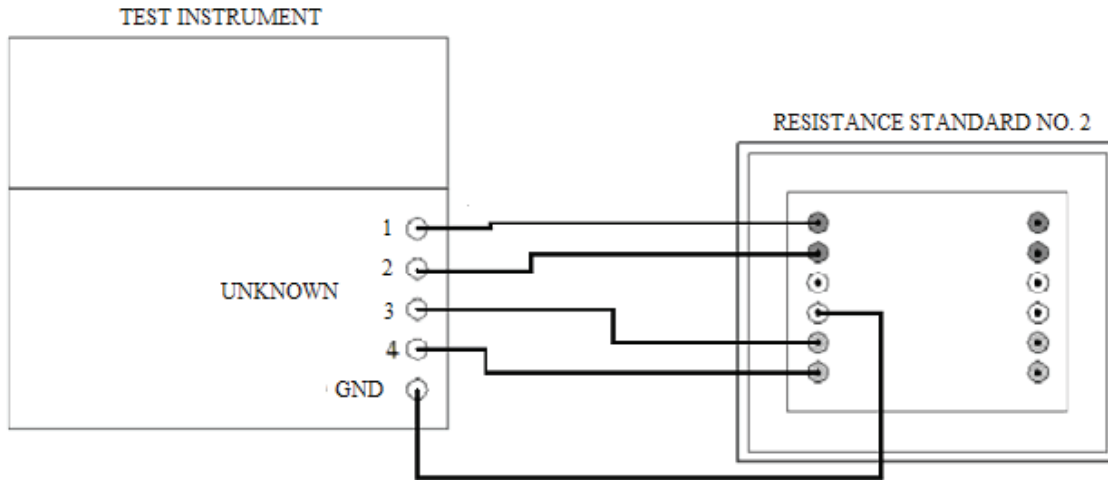

Figure 8. Multiplier - equipment setup.

- (3) Turn **DEVIATION** dial to cc (certified correction) for resistor standard no. 2.

NOTE

Certificate for resistor standard no. 2 will indicate true ohms value. To compute C_{std} , use formula and example below.

$$C_{std} = \frac{R_{std} - R_{nom}}{R_{nom}}$$

Where R_{std} = certificate value of resistance standard
 R_{nom} = nominal value 10 k Ω of resistance standard.

EXAMPLE: Certificate value of resistance standard is 10,000.028 ohms.

$$C_{std} = \frac{10,000.028 - 10,000 \times 10^6}{10,000} = + 2.8 \text{ ppm}$$

- (4) Adjust **DETECTOR ZERO** control for a null indication on TI meter while decreasing **DETECTOR RANGE** switch to **3 MICROVOLTS** range.
- (5) Position controls as listed in (a) through (c) below:
 - (a) **DETECTOR RANGE** switch to **1000 MICROVOLTS**.
 - (b) **FUNCTION** switch to **LEAD ADJ**.

TB 9-4931-217-40

- (c) **GENERATOR OUTPUT +/-OFF/-** switch to + (positive).
- (6) Adjust **LEAD ADJ** control for a null indication on TI meter while decreasing **DETECTOR RANGE** switch to **3 MICROVOLTS**.
- (7) Position controls as listed in (a) through (d) below:
 - (a) **DETECTOR RANGE** switch to **1000 MICROVOLTS**.
 - (b) **GENERATOR OUTPUT +/-OFF/-** switch to **OFF**.
 - (c) **FUNCTION** switch to **YOKE ADJ**.
 - (d) **GENERATOR OUTPUT +/-OFF/-** switch to + (positive).
- (8) Adjust **YOKE ADJ** control for a null indication on TI meter while decreasing **DETECTOR RANGE** switch to **3 MICROVOLTS**.
- (9) Set **GENERATOR OUTPUT +/-OFF/-** switch to **OFF**.
- (10) Repeat (4) through (9) above until no further null adjustment is necessary.
- (11) Position controls as listed in (a) through (d) below:
 - (a) **DETECTOR RANGE** switch to **1000 MICROVOLTS**.
 - (b) **GENERATOR OUTPUT +/-OFF/-** switch to **OFF**.
 - (c) **FUNCTION** switch to **NORMAL**.
 - (d) **GENERATOR OUTPUT +/-OFF/-** switch to + (positive).
- (12) Set **DETECTOR RANGE** switch to **10 MICROVOLTS**. If TI meter does not indicate null, perform **b** (1) below.
- (13) Position controls as listed in (a) through (d) below:
 - (a) **DETECTOR RANGE** switch to **1000 MICROVOLTS**.
 - (b) **GENERATOR OUTPUT +/-OFF/-** switch to **OFF**.
 - (c) **MULTIPLIER** switch to **10 X STANDARD**.
 - (d) Resistance decade dials to 000999.9(TEN)(00).
- (14) Check and, if necessary, repeat (4) above.
- (15) Set **GENERATOR OUTPUT +/-OFF/-** switch to + (positive) and **RANGE** switch to **3 MICROVOLTS**. If TI meter does not indicate null, perform **b** (2) below.
- (16) Repeat technique of (13) through (15) above, using control settings listed in table 17. If TI meter does not indicate null at corresponding **DETECTOR RANGE** switch setting, perform appropriate adjustment listed in table 17.

Table 17. Multiplier Trimmers

DETECTOR RANGE switch settings	MULTIPLIER switch settings	Resistance decade dial settings	Adjustments (behind upper calibration trimmers cover)
10 MICROVOLTS	1 X STANDARD	009999.9 (TEN) (00)	1 MULTIPLIER (R)
10 MICROVOLTS	0.1 X STANDARD	099999.9 (TEN) (00)	0.1 MULTIPLIER (R)
3 MICROVOLTS	0.01 STANDARD	999999.9 (TEN) (00)	0.01 MULTIPLIER (R)

b. Adjustments

NOTE

Remove upper calibration trimmers cover to gain access to adjustments. If adjustments are performed, repeat a above to compensate for interaction of adjustments.

(1) Set **DETECTOR RANGE** switch to **10 MICROVOLTS** and adjust **100 MULTIPLIER** trimmer for null indication on TI meter (R).

(2) Set **DETECTOR RANGE** switch to **3 MICROVOLTS** and adjust **10 MULTIPLIER** trimmer for null indication on TI meter (R).

44. Final Procedure

- a. Deenergize and disconnect all equipment and reinstall TI protective cover.
- b. Annotate and affix DA label/form in accordance with TB 750-25.

By Order of the Secretary of the Army:

GEORGE W. CASEY, JR.
General, United States Army
Chief of Staff

Official:

JOYCE E. MORROW
Administrative Assistant to the
Secretary of the Army

0709201

Distribution:

To be distributed in accordance with STD IDS No. RLC-1500, 2 January 2003, requirements for calibration procedure TB 9-4931-217-40.

Instructions for Submitting an Electronic 2028

The following format must be used if submitting an electronic 2028. The subject line must be exactly the same and all fields must be included; however, only the following fields are mandatory: 1, 3, 4, 5, 6, 7, 8, 9, 10, 13, 15, 16, 17, and 27.

From: "Whomever" whomever@redstone.army.mil
To: <2028@redstone.army.mil

Subject: DA Form 2028

1. **From:** Joe Smith
2. **Unit:** home
3. **Address:** 4300 Park
4. **City:** Hometown
5. **St:** MO
6. **Zip:** 77777
7. **Date Sent:** 19-OCT -93
8. **Pub no:** 55-2840-229-23
9. **Pub Title:** TM
10. **Publication Date:** 04-JUL-85
11. **Change Number:** 7
12. **Submitter Rank:** MSG
13. **Submitter FName:** Joe
14. **Submitter MName:** T
15. **Submitter LName:** Smith
16. **Submitter Phone:** 123-123-1234
17. **Problem:** 1
18. **Page:** 2
19. **Paragraph:** 3
20. **Line:** 4
21. **NSN:** 5
22. **Reference:** 6
23. **Figure:** 7
24. **Table:** 8
25. **Item:** 9
26. **Total:** 123
27. **Text**

This is the text for the problem below line 27.

